

Knight  
by MIDMARK



KNIGHT DENTAL CARTS

UNCOMPROMISING QUALITY

INNOVATIVE DESIGN

## THE ASEPSIS 21™ LEFT/RIGHT DUO CART

WITH A LARGE 21" X 24" STAIN RESISTANT WORK SURFACE AND EASILY CONVERTIBLE DESIGN, THE DUO SWING CART PROVIDES FOR OPTIMUM PLACEMENT OF DOCTOR'S AND ASSISTANT'S INSTRUMENTS.



### DUO SWING CART FEATURES

- ASEPSIS 21 DELIVERY SYSTEM
- HANDPIECE EXHAUST AIR OIL COLLECTOR
- DOCTOR'S SYRINGE WITH QUICK RELEASE AUTOCLAVABLE TIP
- MASTER SHUTOFF
- INDIVIDUAL DRIVE AIR, COOLANT AIR AND COOLANT WATER ADJUSTMENTS FOR EACH HANDPIECE POSITION
- NON-WATER RETRACTING HANDPIECE CONTROLS
- HANDPIECE FLUSH SYSTEM
- WET/DRY FOOT CONTROL
- ASSISTANTS INSTRUMENTATION: SOLIDS COLLECTOR, AUTOCLAVABLE HVE VALVE WITH ASEPTIC TUBING, SALIVA EJECTOR AND ASSISTANT'S SYRINGE WITH QUICK RELEASE AUTOCLAVABLE TIP
- WATER OUTLET WITH FLOW CONTROL
- ADJUSTABLE HEIGHT "H" FRAME WITH EPOXY POWDER COAT FINISH
- 2" DIAMETER DUAL WHEEL CASTERS
- CHOICE OF ROTATING TRAY HOLDER OR TUB SUPPORT
- 21" X 24" WORK SURFACE
- SMALL JUNCTION BOX
- 7 FOOT UMBILICAL

### ASSISTANT'S CART FEATURES

- ASSISTANT'S INSTRUMENTATION: SOLIDS COLLECTOR, AUTOCLAVABLE HVE VALVE WITH ASEPTIC TUBING, SALIVA EJECTOR AND ASSISTANT'S SYRINGE WITH QUICK RELEASE AUTOCLAVABLE TIP
- WATER OUTLET WITH FLOW CONTROL
- ADJUSTABLE HEIGHT "H" FRAME WITH EPOXY POWDER COAT FINISH
- 2" DIAMETER DUAL WHEEL CASTERS
- CHOICE OF ROTATING TRAY HOLDER OR TUB SUPPORT
- 21" X 24" WORK SURFACE
- SMALL JUNCTION BOX
- 7 FOOT UMBILICAL

◀ THE ASSISTANT'S CART HAS PLENTY OF WORK SPACE BY OFFERING THE SAME 21" X 24" STAIN RESISTANT WORK SURFACE AS ON THE DUO CART. THE SWING ARM PROVIDES OPTIMUM PLACEMENT OF ASSISTANT'S INSTRUMENTS.

## THE ASSISTANT'S CART

# THE ASEPSIS 21™ DOCTOR'S CART

THESE COMPACT VERSATILE CARTS GO WHERE THEY ARE NEEDED TO DELIVER THE MOST EFFICIENT PLACEMENT OF DOCTOR'S OR HYGIENIST'S INSTRUMENTS.

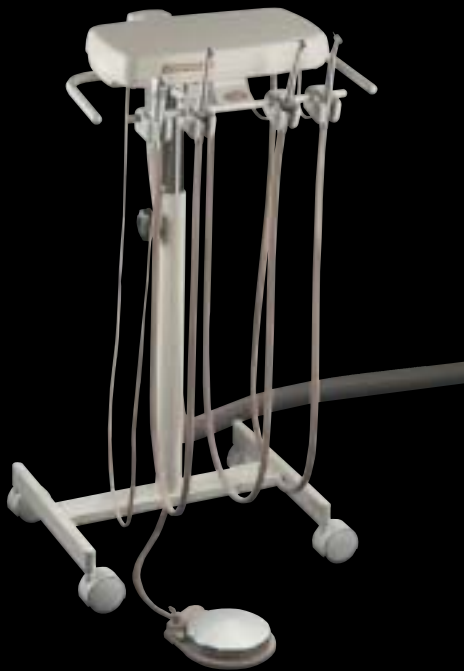

## DOCTOR'S AND HYGIENIST'S CART FEATURES

- ASEPSIS 21 DELIVERY SYSTEM
- VACUUM INSTRUMENTATION INCLUDES SOLIDS COLLECTOR, AUTOCLAVABLE HVE VALVE WITH TUBING AND SALIVA EJECTOR VALVE WITH TUBING. (AVAILABLE ONLY WITH HYGIENIST'S CART).
- HANDPIECE EXHAUST AIR OIL COLLECTOR
- AIR/WATER SYRINGE
- MASTER SHUTOFF
- INDIVIDUAL DRIVE AIR, COOLANT AIR AND COOLANT WATER ADJUSTMENTS FOR EACH HANDPIECE POSITION
- WET/DRY FOOT CONTROL
- HANDPIECE FLUSH SYSTEM
- ADJUSTABLE HEIGHT "H" FRAME WITH EPOXY POWDER COAT FINISH
- 2" DIAMETER DUAL WHEEL CASTERS
- SMALL JUNCTION BOX
- 7 FOOT UMBILICAL

THE HYGIENIST'S CART IS SHOWN WITH THE OPTIONAL 13" X 18" WORK SURFACE WHICH IS ALSO AVAILABLE FOR THE DOCTOR'S CART.

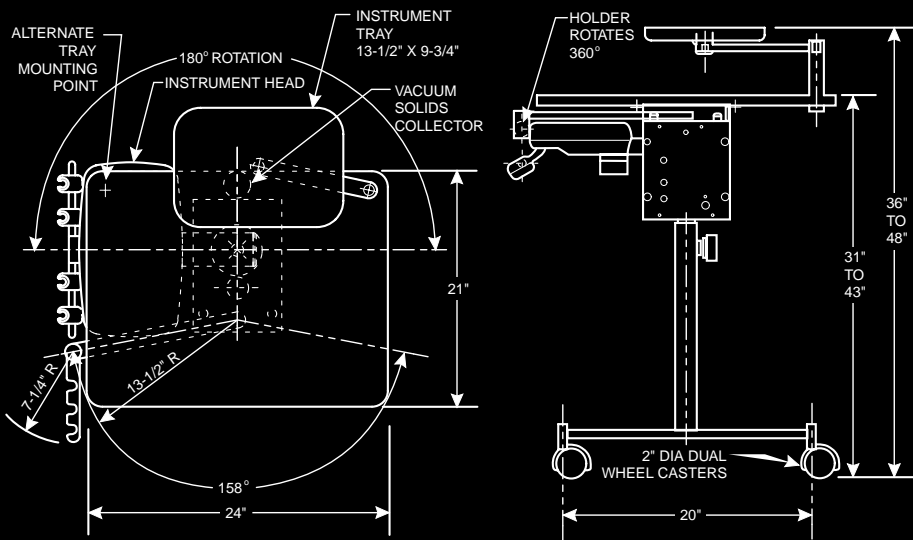

**DUO CART AND ASSISTANT'S CART DIMENSIONS**

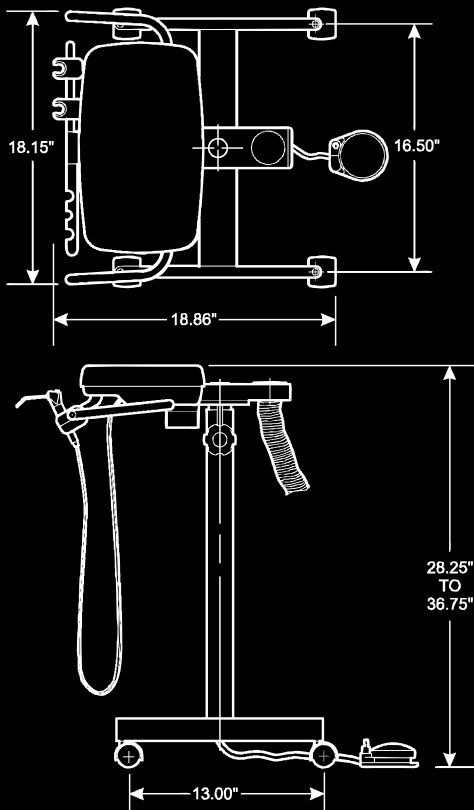

**DOCTOR'S AND HYGIENIST'S CART DIMENSIONS**

MIDMARK IS AN ISO 9001 CERTIFIED COMPANY

**Knight**  
by MIDMARK

FOR MORE INFORMATION OR A DEMONSTRATION, CONTACT YOUR MIDMARK DEALER OR THE MIDMARK CORPORATION.

MIDMARK CORPORATION,  
60 VISTA DR., P.O. BOX 286  
VERSAILLES, OHIO 45380 U.S.A.  
1-800-MIDMARK  
FAX 1-877-725-6495

OUTSIDE THE U.S.A.  
CALL: 1-937-526-3662  
FAX: 1-937-526-8214

midmark.com

© Midmark Corporation 2004  
All products are subject to improvement changes without notice.  
Litho in U.S.A. 007-0500-00 Rev. 6/04